

PRINCESS CORONATION LOCOMOTIVE

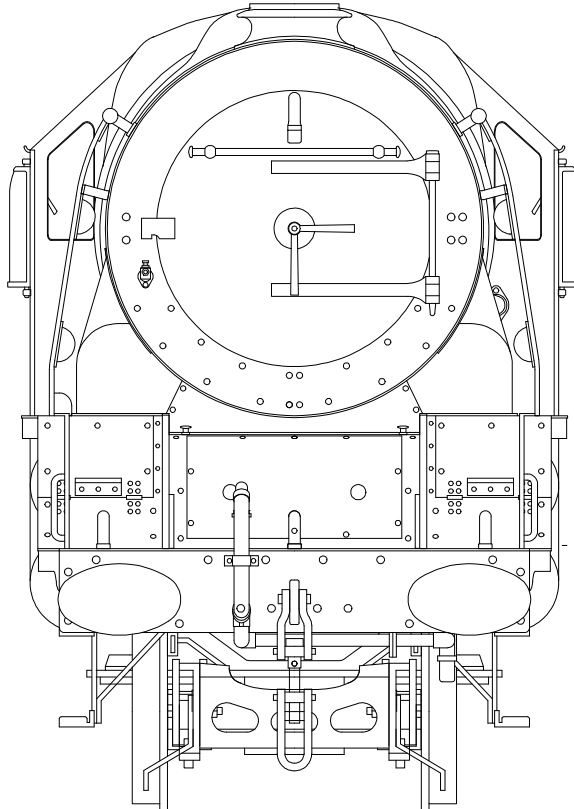

CAUTION.

This product contains etched parts with very sharp edges and castings that may contain lead. Neither the Manufacturer, Distributor or Retailer can accept any liability for illness, injury or consequential damage caused when handling or building this product.

Read any instructions before assembly. Do not eat or drink whilst handling.

Wash hands after use.

BRIEF HISTORICAL DETAILS

The 38 members of the Princess Coronation class, to give the 'Duchesses' their correct terminology, were built at the Crewe Works of the LMS Railway under four lots. The subjects of this kit are the locomotives of the first three lots as follows:

Lot	Numbers	Built	Double Chimney	Streamlining Removed	Smoke Deflectors	Smoke Deflector Footholds	Sloping Smokebox Replaced	BR Speed Indicator
138	6220	6/37	12/44	9/46	11/46	11/46	2/57	Unknown
	6221	6/37	11/40	5/46	5/46	5/46	9/52	11/57
	6222	6/37	8/43	5/46	5/46	5/46	8/53	12/57
	6223	7/37	11/41	8/46	8/46	8/46	8/55	12/57
	6224	7/37	5/40	5/46	5/46	5/46	10/54	10/57
145	6225	5/38	6/43	2/47	2/47	2/47	1/55	10/57
	6226	5/38	7/42	6/47	6/47	6/47	11/55	11/57
	6227	6/38	12/40	2/47	2/47	2/47	5/53	8/57
	6228	6/38	9/40	7/47	7/47	7/47	1/57	10/57
	6229	9/38	4/43	11/47	11/47	11/47	2/57	10/57
	6230	6/38	10/40	N/A	9/46	Yes	N/A	12/57
	6231	6/38	6/40	N/A	9/46	Yes	N/A	Not known
	6232	7/38	1/43	N/A	2/45	Yes	N/A	12/57
	6233	7/38	3/41	N/A	9/46	Yes	N/A	11/57
	6234	8/38	2/39	N/A	3/46	Yes	N/A	10/57
	150	6235	7/39	As built	4/46	4/46	4/46	7/52
6236		7/39	As built	12/47	12/47	12/47	11/53	9/57
6237		8/39	As built	1/47	1/47	1/47	5/56	11/57
6238		9/39	As built	11/46	11/46	11/46	10/53	11/57
6239		9/39	As built	6/47	6/47	6/47	2/57	9/57
6240		3/40	As built	6/47	6/47	6/47	5/57	9/57
6241		4/40	As built	1/47	1/47	1/47	2/58	11/57
6242#		5/40	As built	3/47	3/47	3/47#	11/53	9/57
6243		6/40	As built	5/49	5/49	5/49	11/58	Not known
6244		7/40	As built	8/47	8/47	8/47	7/53	9/57
6245		6/42	As built	8/47	8/47	8/47	12/57	12/57
6246		8/43	As built	9/47	9/47	9/47	5/60	11/57
6247		9/43	As built	5/47	5/47	5/47	5/58	10/57
6248		10/43	As built	12/46	12/46	12/46	6/58	11/57
6249		4/44	As built	N/A	11/46	No	New	9/57
6250		5/44	As built	N/A	3/46	No	New	11/57
6251		6/44	As built	N/A	8/46	Yes	New	9/57
6252	6/44	As built	N/A	3/45	Yes	New	11/57	

From this kit the originally streamlined locomotives Nos. 6220-6229 & 6235-6248 can be built in their de-streamlined condition with the sloping smokebox replaced. These locomotives have the so called 'utility' front platform which is discontinuous in front of the cylinders.

The originally unstreamlined locomotives 6230-6234 & 6249-6252 can be built from new condition. These locomotives have a continuous front platform with a curved drop section.

The originally unstreamlined locomotives 6230-6234 & 6249-6252 can be built from new condition. These locomotives have a continuous front platform with a curved drop section.

No. 6242 was badly damaged in the Harrow & Wealdstone disaster of 1952. After de-streamlining in 3/47 it was given a 'utility' front platform but after repair it reappeared with continuous platforms. It subsequently never received footholds in its new smoke deflectors.

VARIATIONS POSSIBLE WITH THE KIT.

Brake shoes. Nos. 6220-6224 were built with single brake shoes. From 6225 onwards double brake shoes were fitted.

Chimney. Single or double chimney fitted as shown in the table.

Speedometers. Nos. 6230-34 were fitted with a BTH (LMS Type) speedometer when built. A 1944 instruction ordered the removal of all speedometers but photographs show that most were out of use well before this date. On the dates shown in the table all engines were fitted by BR with a Smith-Stone speedometer.

Smoke deflectors. These were fitted to the ex streamlined locomotives at the time they had the streamlining removed. The unstreamlined locomotives had them fitted at the dates given in the table. In May 1955 an order was given for the fitting of footholds in the smoke deflectors of these engines. However not all locomotives were so fitted before withdrawal took place. (See table).

Trailing truck. From inspection of the locomotives in preservation it is clear that the trailing trucks were rebuilt/replaced, we suspect during BR days. The obvious visual change is the widening of the outside frame plates.

Cylinder wrappers. Some engines were fitted with circular access plates whilst others had oval plates.

Cab rear handrails. On nos. 6220-6226 the upper end of the handrail on the rear of the cab was attached by a curved strip. From 6227 onwards a conventional handrail knob was used.

Mechanical lubricator hand levers. These do not appear on Nos. 6230-34 in their early condition.

Sand gun. This was removed circa.1952.

Bogie spring clamps. From inspection of the locomotives in preservation it is clear that the bogies were modified with the addition of these clamps probably in BR days.

Variations/Modifications not incorporated into the kit.

Cylinder bypass valves. Nos. 6220-6224 were built with Fowler-Anderson bypass valves. They were soon blanked off and subsequently removed from all except 6224.

Sloping smokebox top. When streamlined locomotives were de-streamlined they retained their characteristic smokeboxes with the sloping top. These were eventually replaced with fully cylindrical smokeboxes on the dates in the table. We are considering producing a new smokebox casting to reproduce the sloping top if sufficient interest is shown.

Extra washout plugs. Two extra washout plugs were fitted to the boiler in front of the top feed from circa 1946 onwards.

SOURCES OF INFORMATION AND PHOTOGRAPHS

The LMS Pacifics by J.W.P.Rowledge - David & Charles

Locomotives Illustrated 91 - September-October 1993 - RAS Publishing.

The Power of the Duchesses - David Jenkinson - Oxford Publishing Co.

Profile of the Duchesses - David Jenkinson - Oxford Publishing Co.

Stanier Locomotive Classes - A.J.Powell - Ian Allan Ltd.

Loco Profile 37 - J.W.P.Rowledge - Profile Publications Ltd.

The Definitive 'Duchess' - Russell Carter & David Jenkinson - Modellers' Backtrack - Volume 3 Numbers 4 & 5 - Atlantic Transport Publishers.

The Book of the Princess Coronations - Irwell Press

CHASSIS OVERVIEW

Note that many of the components for both chassis and body are handed left/right and care must be taken to ensure the correct component is used. Components are not always identified left/right separately but with care and common sense no problems should arise. Before construction can commence you have to decide which particular chassis you are going to construct. The options are:

Gauge.

For Finescale, where little sideplay is required, the widest spacers can be used but they will need careful filing to make their width 26.0mm. If you require your engine to negotiate sharp curves then the middle width spacers should be used.

The widest frame spacers supplied are suitable for Scaleseven and care will be needed to allow sufficient sideplay, especially in the leading axle to enable the model to negotiate moderate curves.

Suspension.

Rigid. The kit is supplied with top hat bearings to build a rigid chassis. Open out the main axle holes to accept top hat bushes and solder them in place.

Sprung. If you are going to fit sprung horn blocks, you should open out the frame slots by cutting up the half etched lines and follow the manufacturers instructions.

Compensated. The simplest and most reliable suspension system is beam compensation and the necessary compensation beams are provided in the kit. Not provided are the hornblocks and bearings which are available as an extra item which includes instructions for aligning the hornblocks accurately.

Pickups. No pickup material is provided. The options are:

Scrapers. Attached to the middle frame spacer using printed circuit board.

Plunger. Open out holes P and fit according to the manufacturers instructions. It may not be possible to use plunger pickups if you wish to fit the inside motion because they may foul each other.

Split axle/frame. We leave this to you! Some useful information can be found at <http://www.euram-online.co.uk/tips/splitaxle/splitaxle.htm>.

Motor/Gearbox. Not provided - a Canon motor with a SDMP 40L/15 gearbox or an ABC Mini7 gearbox are both recommended.

Wheels. Not provided -

Drivers 6'9", 21 spoke, 13" PB (Slaters 7881ST)
Bogie 3'0", 9 spokes, 5/32" axles (Slaters 7836STMF)
Pony truck 3'9", 11 spoke, 5/32" axle (Slaters 7845SMF).

Bogie Pivot. There are alternatives for the position of the bogie pivot. The choice made will largely determine the radius of curve the locomotive will negotiate.

Inside motion. A separate kit is available to construct the working inside motion.

Nameplate, works plates and other plates. The Princess Coronations had many plates

A pair of nameplates
A pair of oval worksplates for the engine - LMS built 19XX Crewe
A shedplate
A smokebox door numberplate
An oval worksplate for the tender - LMS built 19XX Crewe
A rectangular numberplate for the tender (not fitted to all) - LMS No. XXXX - 19XX.
A capacity plate for the tender - Water capacity 4000 Gallons
A pair of 'Shut water Open' plates for the tender
An 'Out scoop In' plate for the tender
A 'Tender braked to suit 250 lbs press' for the tender

The suppliers are

Guilplates, 32 Wodeland Avenue, Guildford, Surrey, GU2 5JZ Tel 01483 565980/563156

Severn Mill Nameplates, "Bute", Northiam Road, Broad Oak, Rye, East Sussex, TN31 6DS, Tel 01424 883469, e-mail chris@severnmillnameplates.co.uk

OTHER COMPONENTS SUPPLIED IN THE KIT

3/16" bearing (6)	Nickel silver wire - 1.25 mm
5/32" top hat bearing (6)	Nickel silver wire - 1.0 mm
6 BA x 1" screw (2)	Nickel silver wire - 0.8 mm
6BA nut (2)	Nickel silver wire - 0.7 mm
8 BA x 1/4"screw (1)	Brass wire - 1/8"
8 BA x 3/8" screw (2)	Brass wire - 2.0 mm
8 BA x 1/2"screw (1)	Brass wire - 1.4 mm
8BA nut (4)	Brass wire - 1.2 mm
10 BA x 1/4" screw (8)	Brass wire - 1.0 mm
10 BA x 5/16" screw (2)	Brass wire - 0.8 mm
10 BA nut (2)	Brass wire - 0.45 mm
14 BA x 3/16" screw (2)	Steel wire - 1/16"
Self tapping screw - 1/4" (12)	Phosphor bronze wire - 0.7 mm
Valve gear rivet (2)	Copper wire - 1.6 mm
Buffer spring (2)	Copper wire - 1.2 mm
Handrail knob - long (10)	Copper wire - 0.9 mm
Handrail knob - medium (6)	Copper wire - 0.7 mm
Handrail knob - short (4)	Copper wire - 0.6 mm
Brass tube - 1/ 16" outside diameter	Copper wire - 0.4 mm
Brass tube - 3/32" outside diameter	Copper wire - 0.3 mm
Brass tube - 1/8" outside diameter	Rubber tubing
Brass tube - 5/32" outside diameter	Glazing material
Nickel silver wire - 2.0 mm	Screw couplings - (2
Nickel silver wire - 1.6 mm	